

FEMALE END VIEW

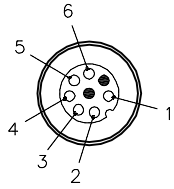

- 1 = BROWN
- 2 = WHITE
- 3 = BLUE
- 4 = BLACK
- 5 = GRAY
- 6 = PINK



SPECIFICATIONS

CONTACT CARRIER MATERIAL	NYLON OR TPU
CONTACT MATERIAL/PLATING	BRASS/GOLD
HOUSING MATERIAL/PLATING	BRASS/NICKEL
RATED CURRENT [A]	2.0 A
RATED VOLTAGE [V]	60 VAC/75 VDC
CONDUCTOR INSULATION MATERIAL	PVC
NUMBER OF CONDUCTORS [AWG]	6x24 AWG
TEMPERATURE RATING	-40°C to +105°C (-40°F to +221°F)
PROTECTION CLASS	MEETS NEMA 1,3,4,6P AND IEC IP68

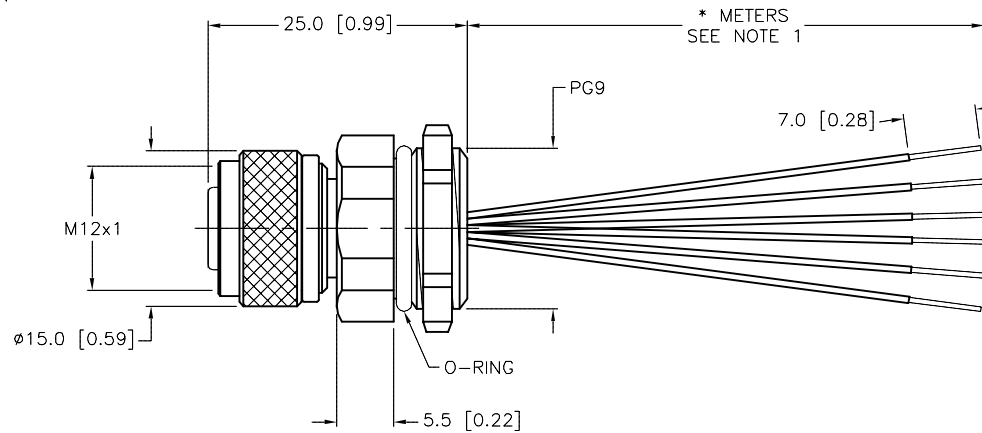
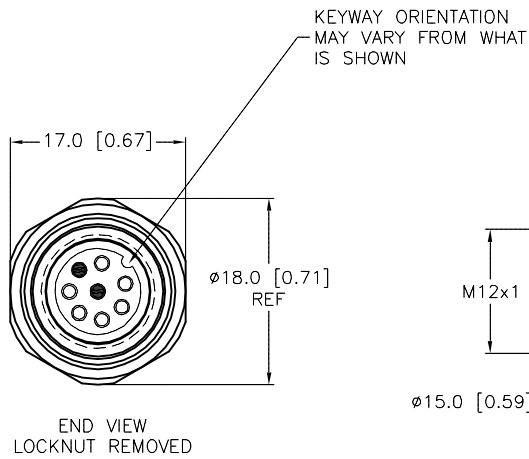

CABLE LENGTH	TOLERANCE*
ALL LENGTHS	+ 4% (OR 50mm) OF LENGTH - 0% (OR 0mm) OF LENGTH WHICHEVER IS GREATER
STRIP LENGTH	TOLERANCE*
0-7mm	±0.5mm
8-29mm	±1.0mm
30-49mm	±2.0mm
50-69mm	±3.0mm
70-100mm	±4.0mm
OVER 100mm	±5.0mm

\* UNLESS OTHERWISE SPECIFIED

NOTES:  
1. "\*" INDICATES LEAD LENGTH IN METERS. CONTACT TURCK TO ORDER SPECIFIC LENGTHS.

SOURCE DRAWING - FOR REFERENCE ONLY

RELATED DOCUMENTS 1. 2. 3. 4.	3RD ANGLE PROJECTION 	THIS DRAWING IS CONFIDENTIAL AND THE PROPERTY OF TURCK INC. USE OF THIS DOCUMENT WITHOUT WRITTEN PERMISSION IS PROHIBITED.		3000 CAMPUS DRIVE MINNEAPOLIS, MN 55441 1-800-544-7769 (763) 553-7300 (763) 553-0708 fax turck.com	
		MATERIAL  SEE SPECIFICATIONS	DRFT JBJ APVD	DATE 04/03/02 SCALE 1=.8	DESCRIPTION  FKM 6-*
FINISH  SEE SPECIFICATIONS	ALL DIMENSIONS DISPLAYED ON THIS DRAWING ARE FOR REFERENCE ONLY  CONTACT TURCK FOR MORE INFORMATION	UNIT OF MEASUREMENT <b>MILLIMETER [ INCH ]</b>		IDENTIFICATION NO.	
DO NOT SCALE THIS DRAWING		FILE: 777001199		REV A	

A	DRAWING RELEASE	RDS	02/04/13	
REV	DESCRIPTION	BY	DATE	ECO NO.